

# William N. Lamarre Concrete Products, Inc.

## 20,000 Tunnel Tank – Fire Cistern

See Full Size 30,000 Fire Cistern Engineered Plan for more information on set up.

Not To Scale

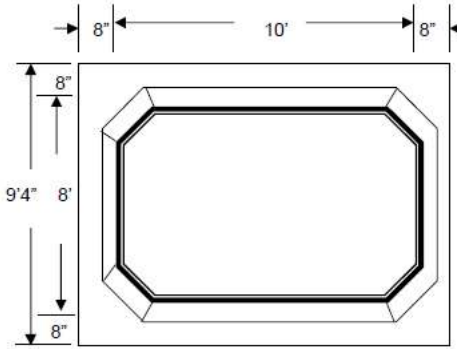
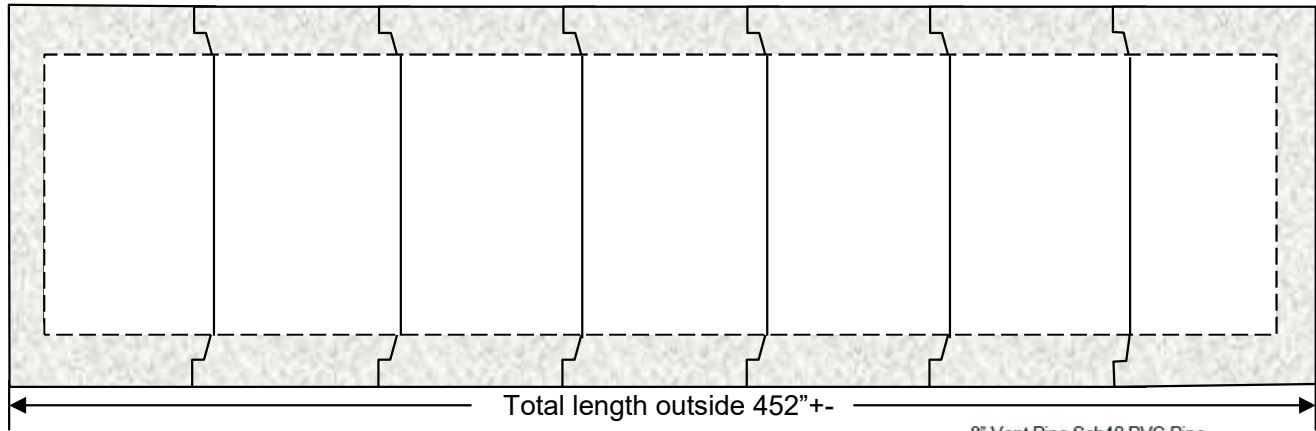

FRONT VIEW

KEY	
(A)	Fill
(B)	Draft
(C)	Vent
(D)	Gauge

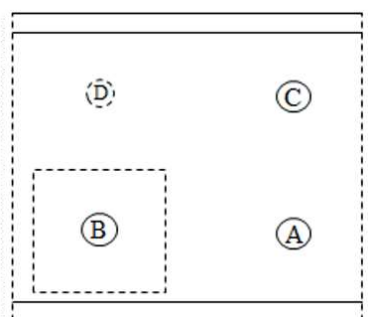

TOP VIEW  
Plumbing Section

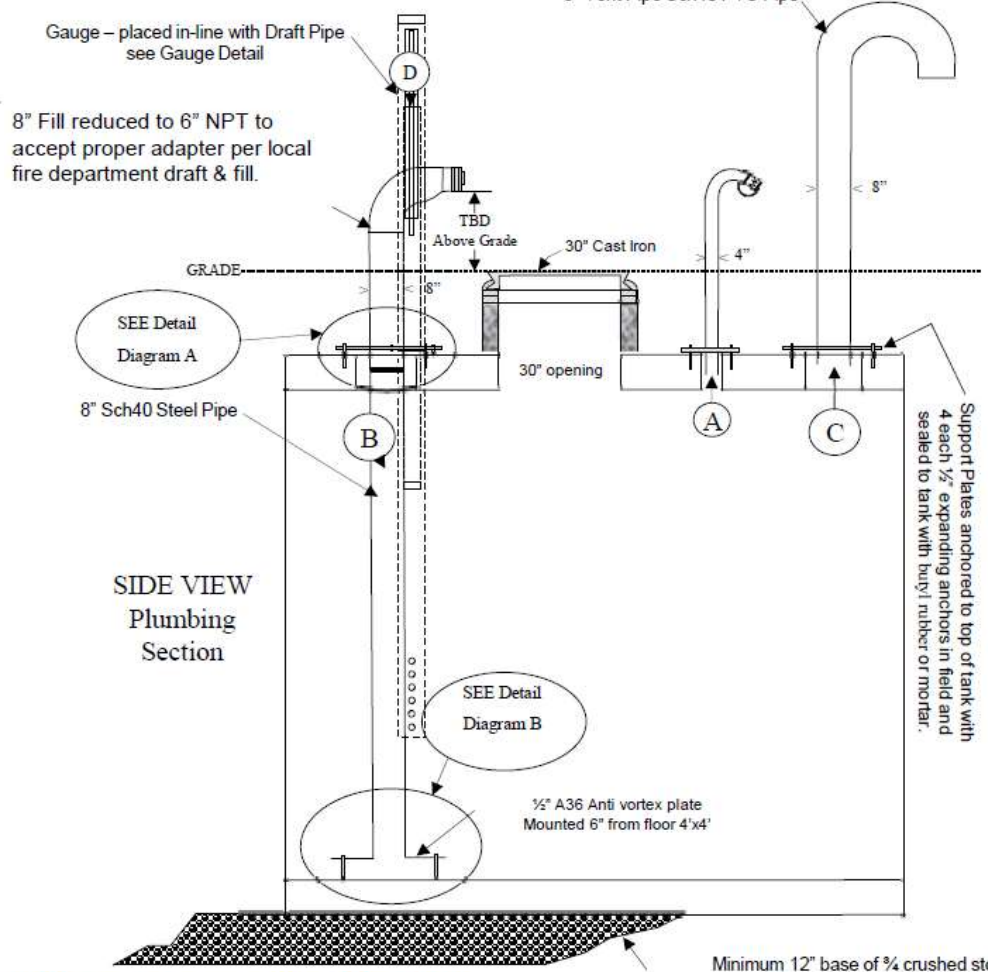

SIDE VIEW  
Plumbing  
Section

### Notes

- Concrete strength  $f_c$  5000PSI@28 days. Density 150 PCF.
- Cement, Portland Type II or III, ASTM C150-81
- Admixtures, air & plasticizers per ASTM C233-82
- Reinforcement per ASTM A615 for wire fabric and Grade 60 rebar
- Design Loading AASHTO HS20-40
- Constructions joints sealed with butyl rubber & grouted after backfill
- Access & Piping per job specs.
- Fire Cistern meets NFPA22 requirements.

20,000 Tank to consist of:  
2-48" ID Ends 28,500# each  
5-68" Centers 23,500# each